

## R&D and System for KEKB Magnet Power Supply

Masato YOSHIDA, Tadashi KUBO, Atsuyoshi AKIYAMA, Tatsuro NAKAMURA, Shinichi YAMAMOTO \*  
 High Energy Accelerator Research Organization  
 1-1 Oho, Tsukuba, Ibaraki 305, Japan  
 \*ATC Co., Hachioji, Tokyo 193, Japan

### Abstract

There are several demands for magnet power supplies of KEKB accelerator. First is high current stability for year and low current ripple. Second is high efficiency and compact. Third is high speed current control for correction magnet power supplies. Fourth is reducing a cost of whole power supply system. After carrying out many R&D, we have solved these problems.

### 1 Introduction

For magnet power supplies of KEKB, required current stability is very severe. Especially, for bending (B), quadrupole (Q), and super conducting quadrupole (QCS) magnet, current stability is 100 ppm(p-p)/ year and magnetic field ripple content rate is 10 ppm(p-p) (>0.2Hz) (1). Even more, currents of correction (St) magnets must be controlled quickly and synchronized the other magnets' currents (2). Much more power supplies (about 2,500) than TRISTAN accelerator must be installed in the existent power supply rooms. These rooms are very small for installation of all power supplies for KEKB and have no air conditioner except for cooling fans. Because of less construction cost in comparison with one of the TRISTAN, we must make power supply to be small and be high efficiency to reduce the cost. Then we decided to introduce new interface system instead of CAMAC to reduce the cost and to satisfy the requirements of the high speed operation for the St magnet.

After many R&D to satisfy requirement for current stability through the year, we decided to introduce very small temperature compensator which contains important parts to realize the high stability. As a result, we have introduced switching mode power supplies to make smaller its size and to reduce the heating loss except for high voltage and large power power supplies. For the interface, we introduced ARCNET (Attached Resource Computer NETWORK) system consists of serial bus (3).

In the next section, we will describe many R&D, and report the whole power supply system including current monitor and interlock system.

## 2 R&D of Power Supply

### 2.1 Temperature Compensator

Before introducing the small temperature compensator, we were going to set the control units of power supplies in air conditioned room (1). However it proved to be the cost is very high and the stability of the temperature is not good. New temperature compensator is very small. Fig. 1 shows a schematic drawing of the temperature compensator. This has a DAC, two burden resistors and an error amp. which are most important parts to realize high current stability of power supply. Fig. 2 shows a block diagram of the parts.

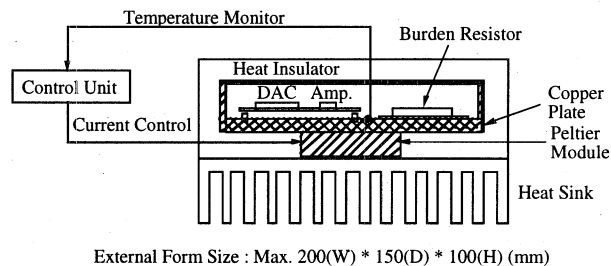

Fig. 1 Temperature compensator for B, Q and QCS.

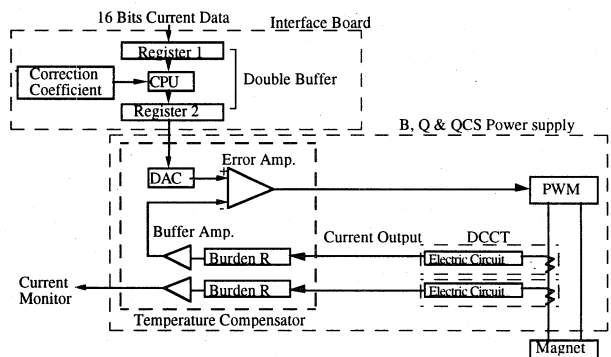

Fig. 2 Block diagram of important parts.

### Temperature Compensator Test

Several performances of temperature compensator made for R&D have been measured. As a result, we decided to use the copper for cooling or heating plate because the change of the resistance value of burden resistor installed on copper plate was less than the case of aluminum plate. We believe that this temperature compensator can control the temperature of plate and inner air within 1.0 degree on all condition.

### 2.2 Important parts

#### 1) DAC (Digital to Analog Converter)

DAC 701LH (unipolar) and DAC703LH (bipolar) are chosen. These DACs have good performance. However it is not sufficient for us regarding temperature and drift characteristic. We will select DACs that have small value of the temperature coefficient (TC) less than 5 ppm/ °C. After that, we will do burn-in for unipolar DACs to reduce the long-term drift less than 30 ppm/ year. Consequently, it is found to be not necessary to cool the surface of DAC by attaching to the plate of temperature compensator (referring in Fig. 1).

#### 2) Error and Buffer Amplifiers

OP 27 are selected as operational amplifiers for error and buffer amplifiers. The long-term drift of this operational amplifier is about 10 ppm/ year because network resistors that have same characteristics will be used to get rid of drift of the gain of the amplifiers.

### 3) DCCT (Current Transformer for Direct Current)

DCCT transforms the current of power supply to low current, and the low current output is applied for input of the burden resistor that set in temperature compensator. DCCT has very small TC in principle except for the transforming circuit from current to voltage. The long-term drift is less than a few ppm/ year. Two types of DCCT are used for the power supplies. It is found one of the types had peculiar ripple and no shield for electromagnetic susceptibility (EMS) (4). Thus we have let the makers to improve it.

### 4) Burden Resistor

This part is used for transforming the DCCT current to voltage (max. 1.0V). Therefore its temperature and current characteristic are very important. Current characteristic is a characteristic for resistance value versus input current. The burden resistors that we use are specially made for us. The change of resistance value is less than 20 ppm from 0 to full current (max. 1.0A). Then the TC and long-term stability are less than 5 ppm/ °C and less than 20 ppm/ year respectively.

### 5) Shunt Resistor

Shunt resistor is used to detect the current of a low current power supply such as St magnet power supply. It is difficult to make the current characteristic well, because the input current is larger than the current of burden resistor. Therefore we made the max. voltage lower (0.1V) to reduce the temperature rise of the resistor. The current characteristic of 5A and 10A shunt became less than 20 ppm consequently. The shunt resistors are also used for beam transport Q magnet power supplies of which max. currents are 30, 50 and 100A. The current characteristic is less than 100 ppm. The long-term stability and TC of these shunt resistor is less than 100 ppm/ year and 5 ppm/ C respectively.

### 6) Total Performance Including Temperature Compensator

As a result of the test of R&D power supplies, total TC of the control unit proved to be less than 10 ppm/ °C. Therefore if we use the temperature compensator, the drift caused by temperature change (10 to 50°C) will be within 10 ppm/ year.

### 7) Gain and Offset Adjustment

We decided not to use trimmer such as variable resistor for adjusting the gain and offset of power supply to save trouble caused by adjustment and to reduce the long-term drift. To adjust the gain and offset, we have introduced digital adjustment that we call it double buffer method. Total errors of gain and offset of all the parts are a few percentages. However we can reduce its error to less than 50 ppm against a standard current monitor by the double buffer method. This method is that the CPU of interface of power supply calculates the corrected set value (on register 2) for DAC from the down loaded set one (on register 1) by using the coefficients for correction stored in the non-volatile memories of the interface.

### 2.3 Switching Mode Power Supply

Several switching mode power supplies made by different makers had been tested for two years. In this paragraph, we report the results.

### 1) Efficiency & Size

The efficiencies of three power supplies of which powers are 20kW (500A, 40V) are over 90 %. On the other hand two power supplies ( $\pm 5A$ ,  $\pm 60V$ ) for St magnets are less than 70 %.

The size of the smallest power supply is 480mm (w), 590mm (H) and 600mm (D). Because 20kW class power supplies are very small, we can set up two power supplies in one rack. The smallest St magnet power supply is 480mm (w), 48mm (H) and 500mm (D). Then we can set up 20 power supplies in one rack.

The switching frequency is important factor to make the power supply small and light. The frequencies of 20kW power supplies are 20kHz except for one (5kHz). The power supply of which frequency is 5kHz is about twice bigger and heavier than the others and noisy because the frequency is within hearing limit. On the other hand the frequencies of two St magnet power supplies are 100kHz and 50kHz. The switching frequencies of power supplies for KEKB are 20kHz for the power supplies above 20kW and 100kHz for St magnet power supply.

### 2) Stability and Ripple

The stability of the prototype power supply (25kW class) is about 20ppm/ 57 hours on condition that the control circuit is in a thermostat, and the ripple is a few ppm. About St magnet power supply made for R&D, the stability is 250ppm/ 87 hours on the same condition as 25kW class one, and the ripple is less than 10ppm. The power supply (25kW class) is satisfied with our requirement, but there is room for improvement of the ripple. St magnet power supply is not satisfied with our requirement for the stability, but it will be improved for KEKB.

### 3) EMI (Electro-Magnetic Interference)

VCCI (Voluntary Control Council for Interference by information technology equipment) class A (for industry) (5) has been adopted for magnet power supplies of KEKB. A prototype power supply (25kw) for KEKB has cleared it for radiated emission level easily. However for the conduction level, it has cleared its level after reinforcing the AC line filter. On the other hand St magnet power supplies have no problem.

### 2.4 ARCNET Interface

There is a communication controller for ARCNET and a CPU on the interface board to control a power supply. It is same as a half size VME board, and its cost is about 17,000 yen. This will be installed into the front panel of the power supply. One port of the VME driver can drive 20 St magnet power supplies at maximum number. Shielded cable (category 5) and connector (RJ 45) has been introduced to protect the circuits from the electromagnetic noise as a result of test. Then synchronized start trigger pulses for all power supplies are distributed from VME driver to interfaces through the same cable of the category 5. ARCNET and start trigger pulse signals are communicated to interfaces by pulse transformer and photo coupler respectively, and the data transfer capability of ARCNET is 2.5Mbps. Therefore 15 St magnets can be controlled synchronously within one second including the data transfer and current setting.

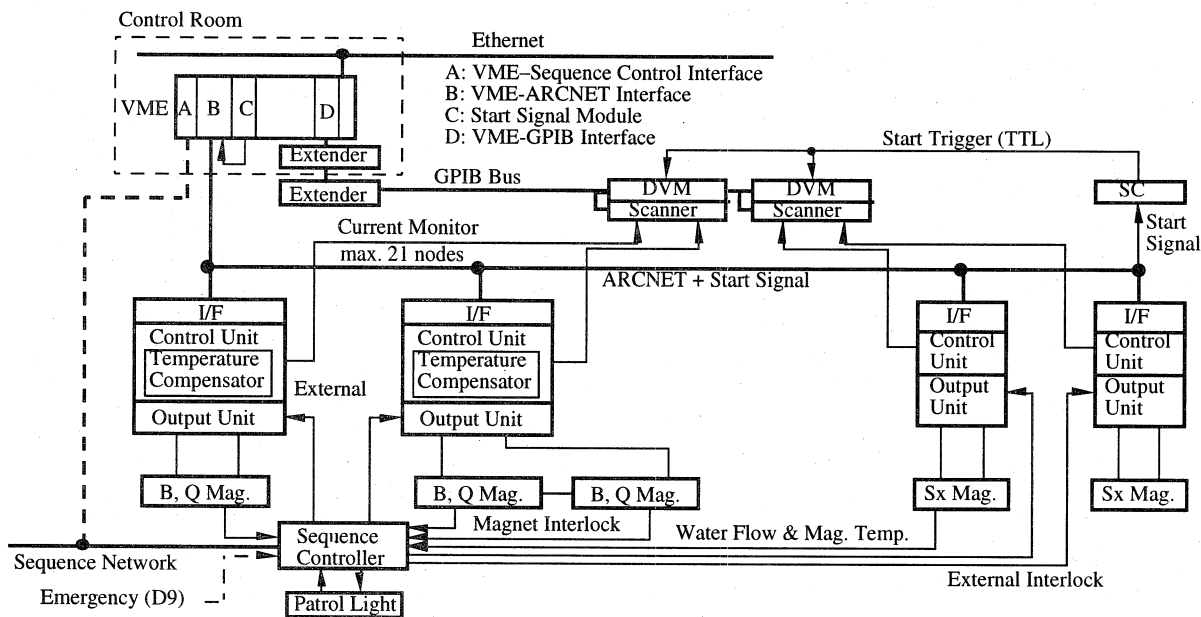

Fig. 3 Block diagram of the KEKB magnet power supply system.

### 3 Power Supply System

#### 3.1 Current Control

Fig. 3 shows a block diagram of the KEKB magnet power supply system. There are two ways to control the current of power supply roughly. One is a way of using start trigger pulse, and the other is a way of using start command. Thus there are two ways of data creation for above-mentioned ways. One is a way of using the linear data calculated by CPU from present set value to target value. The other is a way of using the data that is sent from VME driver and stored in the memory on the interface. The current of St magnet will be controlled by using the start trigger pulse and the data stored in the memory at COD correction.

#### 3.2 Current Monitor System

As shown in Fig. 3, we use GPIB DVMs (Digital Voltage Meter) and Scanners that are in a rack without air conditioner. All current data of power supplies can be taken within 1 or 2 seconds in case of low accuracy mode (error=0.02%). The Accuracy of the current monitor system depends on the accuracy of current monitor output of power supplies and the accuracy of the DVM and scanner system. About the former, exact value of the current can be obtained to use the coefficient of correction for real current such as the double buffer adjustment. This coefficient is stored in the non-volatile memory too. When the long-term drift of gain and the coefficient of correction of particular power supply will be measured, the high accuracy mode of this system will be used.

#### 3.3 Interlock System (Sequence Control System)

This system has a CPU in a main power supply room (D8) and fiber-optic ring to communicate with other system located in 7 power supply rooms, and this network is self-healing type. As a measure against trouble, the CPU has two power supplies for its self.

#### 3.4 Cost

Two things are introduced to reduce the cost of the power supply system. One is providing the important parts to the makers after the public tender. The other is separation of the public tender to several parts such as power supplies (large, middle and little power) current monitor and interlock. As a result, the total cost has been equal to the TRISTAN's, and we think that KEKB power supply system has been made at its best.

### 4 conclusion

As a result of many R&D and the effort of reducing the cost of the power supply system, the high-performance and low cost system will become an accomplished fact. We will set up and adjust all the system from April to August in 1998. We think there will be no trouble because the power supplies will be taken measures to meet EMC (Electro-Magnetic Compatibility) (4) sufficiently.

### References

- (1) T. Kubo et al., "Design of Magnet Power Supplies for KEKB Accelerator", Proc. 10th Symposium on Accelerator Science and Technology, October 1995, pp118-120.
- (2) K. Oide, "Method of Operation for KEKB Magnets", KEK Internal Report, September 1995.
- (3) "ARCNET Technical Manual, Rev. A", Toyo Microsystems Co., August 1997.
- (4) C. R. Paul, "Introduction to Electromagnetic Compatibility", John Wiley & Sons, Inc., 1992.
- (5) K. Ito, "Handbook for Measures of Electric Noise", The Nikkan Kogyo Shinbun, Ltd., August 1994, pp779-780.