

## PLS Computer Control System

S.C. Won, S.S. Chang, Jung-Yun Huang, Jae W. Lee, Jinwon Lee, Jiwha Kim, et al.

*Pohang Accelerator Laboratory,  
POSTECH, P.O.Box 125,  
Pohang 790-600, Korea*

### Abstract

Emphasizing reliability and flexibility, hierarchical architecture with distributed computers has been designed into the PLS computer control system. It has four layers of computer systems connected via multiple data communication networks. This paper will describe the overview of the PLS control system.

### Introduction

The accelerator control system provides means for accessing all machine components so that the whole system could be monitored and controlled remotely. These tasks include setting magnet currents, collecting status data of vacuum subsystem, taking orbit data with beam position monitors, feedback control of electron beam orbit, regulating the safety interlock monitors, and so forth. In order to design a control system which can perform these functions satisfactorily, basic design requirements must be fulfilled. These are reliability, capability, expansibility, cost control, and easy operation.

Considering these requirements, we have worked on the PLS control system structure. After considering PLS accelerator topology, available resources, special accelerator hardware requirements and personal preference, we propose a hierarchical system architecture for the PLS project. On implementation of the control system, a further commercial approach should be made because of the tight construction schedule. We expect that well proven technology could promote the reliability as well as reducing the effort of development.

### Hardware Hierarchy

In order to monitor and control thousands of signals for PLS, it is considered to be desirable and cost-effective to establish a distributed control system based upon microprocessors. Therefore, PLS control system has a hierarchical structure as shown in Fig. 1. The hierarchy consists of four layers of computers, each of which has a different role. The four layers are computing service layer, human interface layer, subsystem control layer, and machine interface layer. The whole computer system constitutes a compound network which consists of a backbone network and multiple subnetworks, as the lowermost two layers are of both functionally and geographically distributed control scheme in order to effectively monitor and control thousands of signals from the machine components which are distributed around the machine.

#### Computing service layer - Host Computer

A host computer which has a high computational speed, large memory, and multiple job capability is chosen for code and data management, mathematical modeling and simulation, off-line analysis, and for general purpose as well. As the emittance of light source decreases, many parameters become more critical and it becomes more important to provide a good computer modeling or simulation of the beam optics. For this purpose, the computation speed should be as high as possible, and it has to be a 32 bit processor with enough physical and virtual memory space.

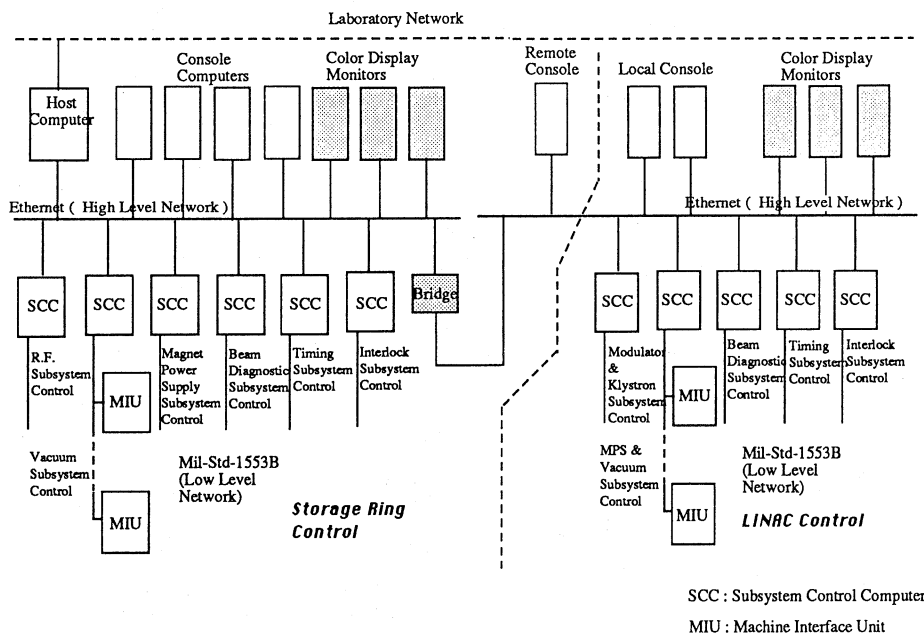

Fig. 1 PLS control system architecture

DEC/VAX SYSTEM™ should be a good choice for this and VMS™ operating system provides an excellent software foundation upon which to run plenty of good software donated by many cooperative accelerator laboratories. However, if we can get easily required software resource which is executable on UNIX™ environment with a little effort, high performance RISC UNIX™ computer might be an alternative.

#### Human interface layer - Console Computers

A mid-range engineering workstation will be used as an operator console to put in the operational parameters and show the operating status. Input parameters will go through some arithmetical processes and be converted into control commands for each partial piece of equipment. These control commands will be forwarded to lower layer of computer system.

Operating status should be shown on color display monitors in the form of simulation diagrams, various kinds of charts, or some other graphical expressions. For a role of this kind, engineering workstation is considered to fit best due to its great computing power with relatively low cost, high resolution color graphics capability, and high performance multiple window display system. DataView™ developed by V.I. Corp. will be used for building a fancy man-machine interface with a little programming effort. A total of four workstations will be used as operator consoles, and few of additional color display monitors are considered for continuous displaying information such as beam current, vacuum status, and magnet power supply current.

#### Subsystem control layer - Subsystem Control Computers

The SCCs are microprocessor assemblies based on the VMEbus and the Motorola 680x0 microprocessor. The reason for adopting the VMEbus is its reliability and popularity. Each SCC consists of one Single Board Computer(SBC), an Ethernet interface module, and a MIL-STD-1553B network interface module, all of which are put together in a VMEbus crate. An SBC with Motorola's 68030 32-bit microprocessor and 4 Mbyte memory is used for the SCC.

SCC does many control and monitor functions, such as reading and setting parameter values of machine components, feedback control, alarm handling, and raw data processing for each subsystem, i.e., vacuum, magnet power supply, R.F., beam diagnostics, timing, and interlock. Each SCC is interconnected to the multi-

ple MIUs through MIL-STD-1553B network. The SCCs are also linked to the high level computers through Ethernet.

#### Machine interface layer - Machine Interface Units

Machine interface units (MIU) are also microprocessor assemblies based on the VMEbus and Motorola 680x0 microprocessor family. Each MIU has one SBC, one MIL-STD-1553B network interface module, and a number of analog and digital input/output modules, all of which are put together in one or more VMEbus crates. An SBC equipped with Motorola's 68000 16-bit microprocessor and 1 Mbyte memory is used for the MIU. In order to handle various types of analog and digital input/output signals, a wide range of standard analog and digital input/output modules as well as home-made or non-standard interface modules are used. MIUs are distributed around the machine to reduce the length of the signal cables between the MIUs and the machine components and also to reduce the electromagnetic noise problems on the cables. Multiple VMEbus crates in the MIU are interconnected through VMEbus-to-VMEbus repeater module.

#### Data Communications Network

The components of PLS control system are linked via two levels of data communication network; low level and high level network. The low level network is used for data acquisition and forwarding of control commands. The high level network delivers operational setpoint values to the lower level of computers and information acquired by the lower level of computers to the console computers.

The low level network must be tolerant of electro-magnetic noise because MIUs should be installed close to various noise-generating equipment and cable. Due to this requirement, MIL-STD-1553B specification is considered. MIL-STD-1553B is a multi-drop network specification which is operated in a master/slave mode on which one Bus Controller(BC) may communicate with upto thirty Remote Terminals(RT). SCC acts as BC and MIU as RT.

For the high level network, Ethernet is chosen because it has a forte of popularity and therefore allows cheap and easy implementation for both hardware and software. TCP/IP will be adopted as higher layer protocol for the same reason. Ethernet

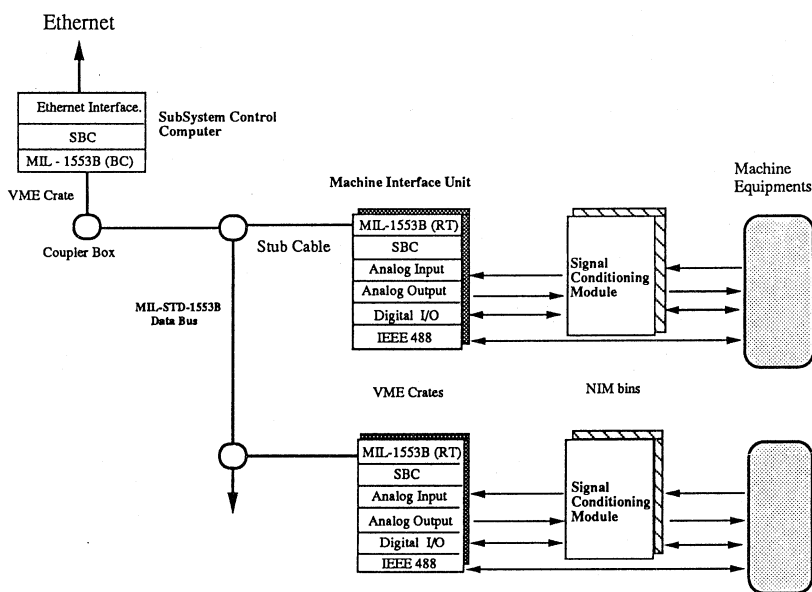

Fig. 2 Structure of data acquisition and control system

is a CSMA/CD network with a maximum transfer rate of 10 Mbps. However, the length of transmitted packet and transmission speed must be carefully selected to guarantee the appropriate transfer delay time and throughput.

## Software

### System software

Real-time operating system should be used for the SCCs and MIUs because some machine control jobs such as closed orbit correction requires real-time performance. OS-9™ from Microware Systems is selected because of its advanced kernel functions and variety of software development tools.

The database on the SCC has the whole subsystem parameters. It also has the component table which acts as a name server providing the translation between the different symbolic names allowable at the high level and signal names in the MIUs, as well as linking these names with addresses of the MIU concerned. The database at the MIU contains component data such as hardware addresses, set values, limits, conversion and calibration factors, and so forth.

### Machine control software

Operating status of each subsystem such as vacuum, R.F., and magnet power supply subsystem should be displayed or archived to files, which might be later processed to analyze the operating history by plotting various kinds of charts.

Desired setpoint values such as magnet power supply current and cavity gap voltage should be set. Setpoint values and other operational parameters might be put into the control system manually by the operator or automatically by proper control software.

Intolerable differences between setpoint values and corresponding readback values should be continuously monitored and reported to the operator. They are archived in files at the same time. The differences might be compensated by slow feedback control program as long as there is no serious failure in correction. Continuous failure in correction would result in alarm situation, which would be reported to the operator immediately. Any fault in apparatus should be reported to the operator, who might cope with it properly.

### Database

A comprehensive database defines all machine parameters and device signals. The database is generated in one of the console computers. The generated database consists of two parts: static and dynamic part.

The static database includes static machine parameters and device information such as names, locations, and various coefficients which might be used to convert scientific unit into actual signal values, and vice versa.

Generated static database should be shared among the console computers by transferring the same copy of static part and keeping consistency between the original and copies. Appropriate part of static database should be downloaded to SCCs to be

used to control each subsystem properly. SCC might recursively download parts of its static database to MIUs under control. MIUs use this static database to convert scientific setpoint values into actual control signal values or actual monitoring signal values into scientific readback values.

The dynamic database consists of setpoint values such as magnet power supply currents and cavity gap voltages, and readback values such as ion gauge currents, magnet power supply currents and cavity gap voltages.

Dynamic database on console computer has just a structure at the very beginning. It might be filled with valid data, when a control process which might need appropriate data were spawned. The valid data should be transferred from the appropriate SCC to the requesting console computer on "Supply-On-Demand" basis. This scheme maximizes the network throughput by keeping unnecessary data from being transferred via network. Resulting gain in network capacity could be used for faster data acquisition of any particular signal group. Setpointing might also cause updating part of dynamic database with setpoint values.

### Beam diagnostic software

Knowledge of the accurate machine parameters is very important for the efficient operation and study of the machine. We are going to automate all the beam diagnostic processes with various beam diagnostic programs such as beam orbit measurement, real time orbit correction, tune measurement, beam lifetime, beam emittance, and lattice function measurement, etc. Some diagnostic software will be run at the low level control computers for the real time beam diagnostics and feedback.

### Modeling and simulation software

Traditionally commissioning of particle beamlines is a very time-consuming and laborious task. Even in day-to-day operation after start-up, various types of machine and beam errors have to be corrected. To reduce the time and effort for these tasks, computer programs both easy to use and sufficiently fast are needed.

## Conclusion

The most important requirement in designing PLS control system is flexibility. Natural growth of the system will require expansion of control system or more complex control of the accelerator, and it is often necessary to implement new technology on the existing control system. Hence the control system should be designed flexibly enough to handle this expansion.

## References

1. S.C.Won, Jae W. Lee and Jinwon Lee, Computer control system, PLS Conceptual Design Report, (Jan. 1990, POSTECH, Korea)
2. S.C.Won, Jae W. Lee and Juno Kim, Computer control system for PLS, Proc. of the 4th Asia Pacific Physics conference, (Aug. 1990, Seoul, Korea)
3. S.C.Won, Jinwon Lee and Jiwha Kim, DACS(Data Acquisition and Control System) for PLS, Proc. of the 4th Asia Pacific Physics conference, (Aug. 1990, Seoul, Korea)