

BEAM POSITION MONITORING AND ANALYSING SYSTEM IN KEK

D. Arakawa, H. Ishii, J. Kishiro and S. Hiramatsu
National Laboratory for High Energy Physics, Japan

We developed beam position monitoring system and the method of analysing the position data in order to correct the closed orbit and to obtain the momentum error in the proton synchrotron in KEK. The closed orbit correction can be performed within an accuracy of 0.5mm using this monitoring system. The closed orbit distortion is caused from the perturbing magnetic field and the momentum error of the beam, simultaneously. In our analysis, these sources of the closed orbit distortion can be obtained independently.

Monitoring system

The system contains following five instruments (Fig. 1). The first; fifty-six electromagnetic pick-ups¹⁾, which, shown in Fig 2, has four segmented inner pipe to detect the horizontal and vertical beam position, simultaneously. The second; 224 amplifiers are installed in the accelerator room. An amplifier contains a low pass filter with high frequency cut-off of 11 MHz and a rectifier which picks up the beam position signal superimposed on the beam signal. The third; four multiplexers and two normalizers. The normalizer acts as a converter from the raw signal detected by the segments to the position one. The fourth is the computer interfaces and the last is a superintendence circuit to the default of the monitoring instruments.

The beam signals are not only displayed on a CRT without computer handling but also analysed by a computer.

Analysing system

The position data are analyzed with the undetermined coefficient method²⁾. The closed orbit distortion at the k-th position monitor (x_k) can be represented as follow;

$$x_k = \sqrt{\beta_k} \sum_j A_{kj} \theta_j + \eta_k \frac{\Delta p}{p} \quad (1)$$

where

$$A_{kj} = \frac{\sqrt{\beta_j}}{2\sin(\pi\nu)} \cos\nu\{\pi - |\psi_k - \psi_j|\} \quad (2)$$

$$\theta_j = \frac{\Delta(BL)_j}{B\rho} \quad (3)$$

ν , ψ and β are the ordinary accelerator parameters, the tune, the phase and the β -function. $\Delta(BL)_j$ and η_j are the perturbing field and the dispersion function at the j-th position around the accelerator, respectively.

To obtain the perturbing field, we must minimize following equation;

$$B = \sum_j \theta_j \quad (4)$$

And the solution of the above equation have a constraint that the corrected orbit should be a central orbit;

$$C_k = x_k - \sqrt{\beta_k} \sum_j A_{kj} \theta_j - \eta_k \frac{\Delta p}{p} \quad (5)$$

The equation to be solved is obtained by varying θ_j and η_j and imposing the constraint (5) with the Lagrange multipliers λ_k ;

$$\sum_j (\theta_j - \sum_k \lambda_k A_{kj}) \delta\theta_j - \sum_k \lambda_k \delta(\eta_k / \sqrt{\beta_k}) \frac{\Delta p}{p} = 0 \quad (6)$$

The solutions of (6) are;

$$\theta_j = \sqrt{\beta_j} \sum_{m,n} N_{mn}^{-1} (x_n / \sqrt{\beta_n} - \eta_n / \sqrt{\beta_n} \frac{\Delta p}{p}) A_{mj} \quad (7)$$

$$= \frac{\sum_{m,n} N_{mn}^{-1} \eta_m x_n}{\sum_{m,n} N_{mn}^{-1} \eta_m \eta_n} \quad (8)$$

where $N_{mn} = \sum_i A_{mj} A_{nj}$.

Thus we can obtain the perturbing field and the momentum error independently.

The correction of the closed orbit is carried out by the backleg windings of the bending magnet corresponding to the current generating $\Delta(BL)_j$. The advantages of our analysis is that the correction of the perturbing field can be performed without regard to the correction of the momentum error, which should be performed by RF frequency tuning, Fig. 3. Fig. 4 shows the measured and corrected orbit. We can correct the perturbing field with a single manipulation by reason of the independency between field and momentum error.

These systems are now in use to accelerator operation and contributes to accelerator study, sufficiently.

References

- 1) K. Satoh Rev. Sci. Instruments 50(1979)450
 D.Arakawa, S.Hiramatsu, H.Ishii, J.KIshiro and K.Satoh
Proc. on 3rd Sympo. on Accelerator Sci. and Technology
 osaka, Japan p169(1980)
- 2) J.C. Herrera and E.G. Gill IEEE Trans. Nucl. Sci., NS-20,p872,1973

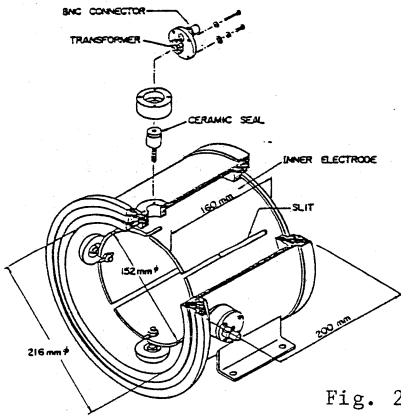

Fig. 2

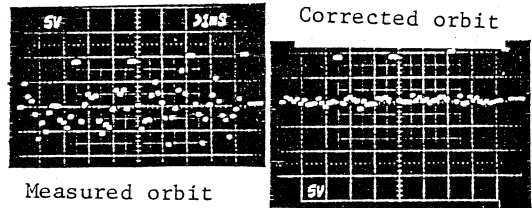

Fig. 3

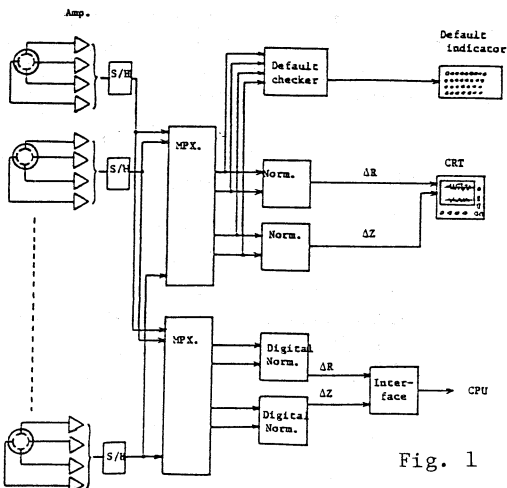

Fig. 1

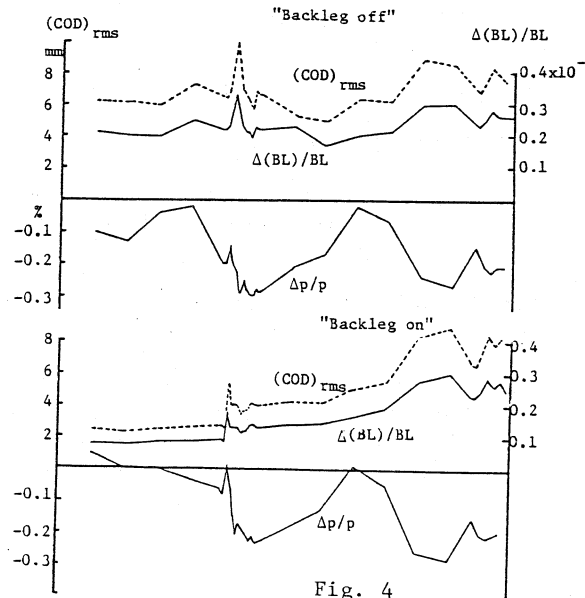

Fig. 4