

THE FOUR-MIRROR LASER STACKING CAVITY FOR POLARIZED GAMMA-RAY/POSITRON GENERATION

F. Labaye, E. Cormier, CELIA CNRS Université Bordeaux 1, Bordeaux, France
T. Akagai, S. Miyosohi, S. Nagata, T. Takahashi, Hishoshima University, Hiroshima, Japan
S. Araki, S. Funahashi, Y. Honda, T. Omori, H. Shimizu, T. Terunuma, J. Urakawa, KEK, Tsukuba, Japan
J. Bonis, R. Chiche, R. Cizeron, M. Cohen, J. Colin, E. Cormier, P. Cornebise, D. Jehanno, F. Labaye, M. Lacroix,
Y. Peinaud, V. Soskov, A. Variola, F. Zomer, LAL CNRS/IN2P3 Université Paris-Sud 11, Orsay, France
R. Flaminio, L. Pinard, LMA CNRS/IN2P3, Lyon, France
K. Sakaue, Waseda University, Japan

Abstract

A non planar four mirror cavity has been designed and constructed to demonstrate the production of high gamma ray fluxes from Compton scattering of laser and electron beams at ATF. A pulsed laser is amplified using the recent technology of Yb-doped photonic cristal fibres. Seeding the high finesse four-mirror cavity with this amplified laser beam will allow reaching average powers between 0.1MW and 1MW.

INTRODUCTION

The future linear colliders will operate with polarized positrons. Among the possible technical solution which will provide a positron source, the Compton scheme is the most attractive [1]. Proof-of-principle demonstrations were performed to show generation of polarized γ -rays [2] and polarized positrons [3]. However, the laser beam – electron beam Compton cross-section smallness induces a strong constraint on the laser beam power. To reach the required power, we propose to use a non planar four-mirror Fabry-Perot cavity. A two mirror cavity has already been operated successfully at ATF [4,5]. Our new cavity will be able to enhance the laser beam power by factors up to 10000 and its special geometry provides circularly polarized mode [6,7], a small beam waist and a high stability level against environment perturbations [6].

To prove these properties, such a cavity has been designed and constructed in order to be installed in the ATF ring during the summer 2010 shutdown. In a first step, the cavity power enhancement factor will be of the order of 1000 and the incident laser beam average power will be around 50 W. In a second step, after the commissioning of the system in ATF, the enhancement factor will be increased by an order of magnitude and the incident average power by a factor 3 to 4. Our goal is to increase the laser beam power inside the cavity above 100 kW, up to the Mega Watt level.

This contribution describes the optical cavity, the related optical setup and its implementation in the ATF ring. In section 1, the laser system is described. The four mirror cavity is described in section 2 and the feedback scheme in section 3. The status of the experiment is given in section 4.

THE LASER SYSTEM

Fig. 1 shows the optical setup. A low noise and low power, mode locked laser (ORIGAMI from ONEFIVE Inc.) provides 500 fs pulses at 178.5MHz. In order to operate the Pound-Drever-Hall feedback technique, the laser beam is modulated in frequency by an electro-optical modulator (eom). Because of the limited section of the amplifying fiber core in which the laser beam is confined, the pulses are initially stretched to significantly reduce the intensity in the fiber and therefore limit the non-linearities during amplification. This technique known as chirped pulse amplification is widely used in high power fs laser systems. After amplification the pulses are recompressed in the compressor unit down to the electron collision required duration of 20 ps. The amplifier consists in a diode pumped double clad photonic crystal Yb-doped fibre. We obtained average powers of the order of 150W but we observed some instabilities. In the first step of experiment in ATF, the amplifier is limited to a stable 50W to 60W average power. Meanwhile, developments are conducted to provide the nominal 150 W stable average powers compatible with cavity locking.

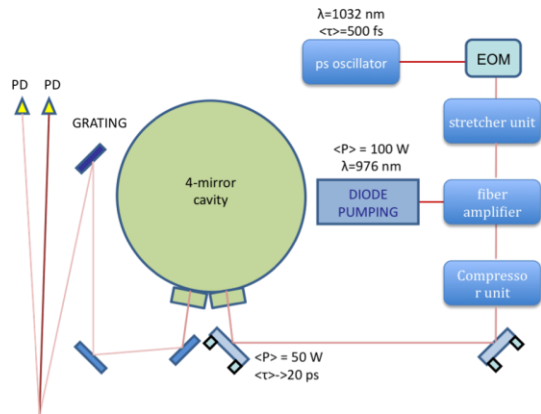

Fig 1: Optical scheme, see text.

THE FOUR-MIRROR CAVITY

The geometry of the four-mirror cavity is shown in fig. 2. The non planar tetrahedron shape exhibits technical advantages with respects to the standard two-mirror or planar four-mirror cavity: a good mechanical stability even with very small spatial mode waits; circularly polarized eigen modes[3,4], as requested for the polarized positron source; stability of the eigen mode polarisation against mirror misalignments and motions induced by the environmental noises[3].

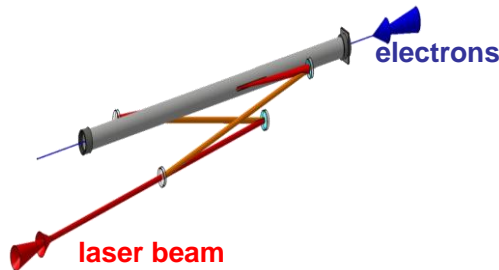

Fig 2: Geometry of the four-mirror cavity. The upper mirrors are spherical while those below are flat.

The geometry of the four-mirror cavity is shown in fig. 2. The non planar tetrahedron shape exhibits technical advantages with respects to the standard two-mirror or planar four-mirror cavity: a good mechanical stability even with very small spatial mode waits; circularly polarized eigen modes, as requested for the polarized positron source; stability of the polarisation eigen mode against mirror misalignments and motions induced by the environmental noises.

A technical drawing of the cavity constructed for ATF is shown in fig. 3. in order account for the 5mm beam pipe aperture width (see fig 2 and 3) a very precise gimbal mirror mounting system has been designed. Stepper

motors are encapsulated inside metallic cylinders and provides micrometric mirror alignments. The first vacuum tests performed at Orsay in spring 2010 met the strict request imposed by the world smallest-class emittance of ATF.

The very low loss mirror coatings (below 1ppm) were made at Lyon.

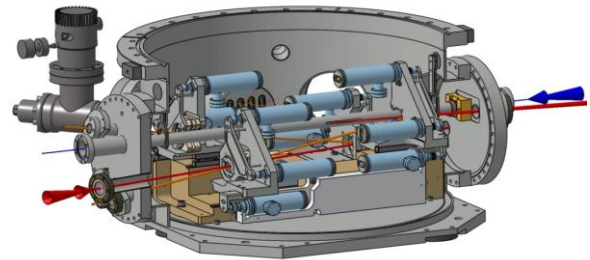

Fig 3: technical drawing of the cavity installed at ATF

THE FEEDBACK SYSTEM

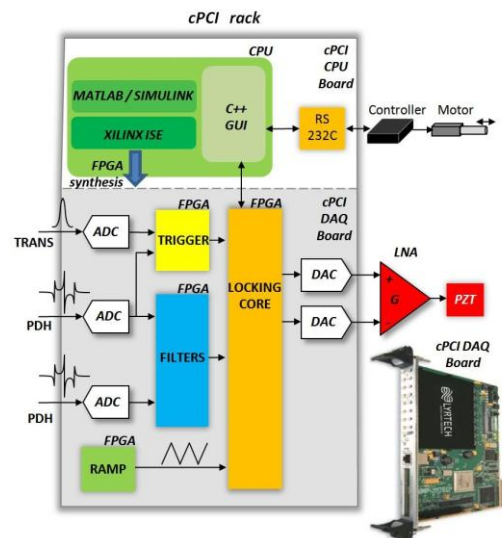

Fig 4: Schematic view of the Digital feedback scheme.

A Digital Feedback System is used (see Fig. 4). It is embedded inside a large (8×106 gates) Xilinx FPGA and an 8×ADC and 8×DAC of both 14 bits and both working synchronously at about 108 samples per second (the board is from the Lyrttech Inc.). The digital board is for fast/synchronous purpose and a PC with a C++ GUI is used for the slow control. The system consists in several parts:

- A scanning block to produce permanent peaks in transmission of the FP cavity. It uses a temperature control of the laser cavity to explore the frequency domain with a wide range, directly from the GUI, until some peaks are found in transmission of the FPC. Next, a ramp is supplied on the PZT to finely cross cavity resonances. The ramp can be chosen from the GUI.

- The Trigger block: the user can set a Trigger level inside the GUI on these transmission peaks, acquired by the DAQ, to send a trigger signal to start the linear locking.
- The Filter blocks: feedback error signals are read by the board and filtered by two sets of Second Order Section (SOS) Filters. These filters are essentially integrators to reduce the low frequency noise as much as possible. Some tricks are needed to make these SOS Filters properly work with fixed point arithmetic inside the FPGA.
- The Locking Core is the "director" of all these signals. It contains the state machines to manage all the signals.

The digital system has a latency time of 60 ns. By reducing at most the electronic noise we were able to lock to a good level of stability our four-mirror cavity in Orsay in June 2010. In addition, we used the same feedback system to lock a Ti:sapph oscillator to a 30000 finesse two-mirror-cavity. This gives us thus some confidence to the capability of our feedback system to lock the four-mirror ATF cavity at the same finesse level.

STATUS AND SUMMARY

As mentioned above, a tetrahedron four-mirror cavity and an amplified laser beam have been constructed and tested successfully. The cavity enhancement factor is about 1000 and the incident laser beam average power is ~50W. Therefore, the available potential power inside the cavity can reach the 50kW level with an attenuation factor of 20% to 50% due to imperfect coupling attributed to mode mismatch environmental noises.

The whole setup is being installed at ATF since the 26th of July 2010 (see fig 5) and will be hold by the KEK micrometric mounting systems (see also fig 5).



Fig 5: Installation of the four-mirror cavity in ATF.

ACKNOWLEDGEMENT

This project is funded from the French side by National Agency ANR and by the IN2P3/CNRS and the French-Japanese Collaboration benefits from the FJPPL resources.

REFERENCES

- [1] S. Araki et al. Physics/0509016, KEK Preprint 2005-60, CLIC note 639, LAL/05-94.
- [2] M. Fukuda et al., Phys. Rev. Lett. **91**, 164801 (2003)
- [3] T. Omori et al., Phys. Rev. Lett. **96**, 114801, (2006)
- [4] H. Shimizu et al., J. Phys. Soc. Jap. 78 (2009) 074501.
- [5] S. Miyoshi et al., arXiv:1002.3462
- [6] F. Zomer et al., Appl. Opt. (2009) 6651.
- [7] Y. Honda et al., Opt. Comm. 282 (2009)3108.