

HIGH-POWER TESTS OF REPAIRED CIRCULATOR FOR LIPAc RFQ

K. Hirosawa[†], N. Kubo, A. De Franco, K. Kondo, K. Masuda, A. Kasugai, M. Sugimoto, Quantum National Institutes for Quantum Science and Technology (QST), Aomori, Japan
I. Moya, F. Scantamburlo, Y. Carin, Fusion for Energy (F4E), Garching, Germany
L. González-Gallego Sánchez-Camacho, C. Caballero, J. C. Morales Vega, University of Granada (UGR), Granada, Spain

Abstract

The Linear IFMIF Prototype Accelerator is the accelerator facility to validate the engineering design of the International Fusion Materials Irradiation Facility (IFMIF). The first stage of the IFMIF accelerator up to 9 MeV for 125 mA deuteron beam in continuous wave (CW) mode is the design configuration of the LIPAc. The 9.8 m long RFQ, which is one of the most important accelerating components despite extremely strong space charge force, is fed by 8 RF drive sources. They are synchronized with the White Rabbit based solution and each include 200 kW amplifier system including their circulator. During the RFQ CW commissioning campaign in January 2022, one circulator had frequently arc trouble leading to severe damages at the connection of the inner transition from the coaxial line output of the final tetrode to the strip-line central plate of the circulator. The damaged circulator was repaired at the manufacturer's factory premises and tests of RF characteristics were performed after its reinstallation in LIPAc. An overview of the encountered issues and repair, evaluating the parameters, and the points we found in the high-power test.

INTRODUCTION

LIPAc (The Linear IFMIF Prototype Accelerator) is the accelerator to validate lower energy part of the design of IFMIF, which is the neutron source for the test facility of the materials for the fusion reactor. In the design, the system is aiming to accelerate the 125 mA-CW deuteron beam up to 9 MeV. We are now in the stage of intermediate of the full commissioning, so-called Phase-B+, which is positioned between the Phase-B, RFQ acceleration, and the Phase-C, superconducting RF cavity and the high-power beam dump.

We had a beam commissioning to validate the system RFQ acceleration with the low energy beam dump, 125 mA 1 ms pulse is successfully accelerated in 2019. In present, the accelerator construction has been done, except for the cryomodule linac, which can accelerate the beam from 5 MeV to 9 MeV, and the beam operation was started in June of 2021. In parallel of the beam, RFQ commissioning to be reached to CW, but then the destructive sparks are happened in the transition part of a circulator, used to circulate the reflection power. In addition, during the optional challenge to drive RFQ with 7 RF stations, vacuum leak from RF power couplers was happened. Because of above two points in the R F system, a long maintenance term was

spent to recover the system over one year. The beam commissioning has been resumed from July of 2023.

The topic summarized in this report consists of the failure and repair of the circulator, evaluating parameters to see the effect of temperature and intensity of magnetic field, and the high-power loading test of full RF power operation.

RF SYSTEM

Overview of the LIPAc RF System

The LIPAc RF system consists of the source and its amplifiers for 1-RFQ, 2-Re-Bunchers, and 8-SRF cavities. The control system is based on one typical design [1], shown in Fig. 1, used in the Re-buncher cavity. In addition to the base model, Master-Slave control loop is implemented but tuner is removed for the RFQ, because the resonance tuning is realized by cooling water loops.

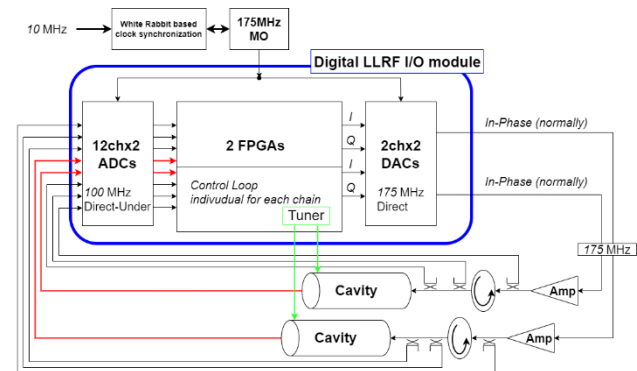

Figure 1: Schematic of the RF control loop.

The amplification system is also same for the RFQ and the SRF cavities. Based on the tetrode RF power amplification and the circulator works to isolate the external impedance between the amplifiers and RF cavities [2-5]. The difference between these two type of cavities is just component sizes coming from the estimation of the possible ohmic loss in the circulator and the coaxial lines. The RFQ and SRF system are required to provide 250 kW-CW and 150 kW-CW power, respectively. The control system is driven with the very precise clock reference system based on the White Rabbit synchronization protocol, which has sub-nano second scale precision.

[†] hirosawa.koki@qst.go.jp

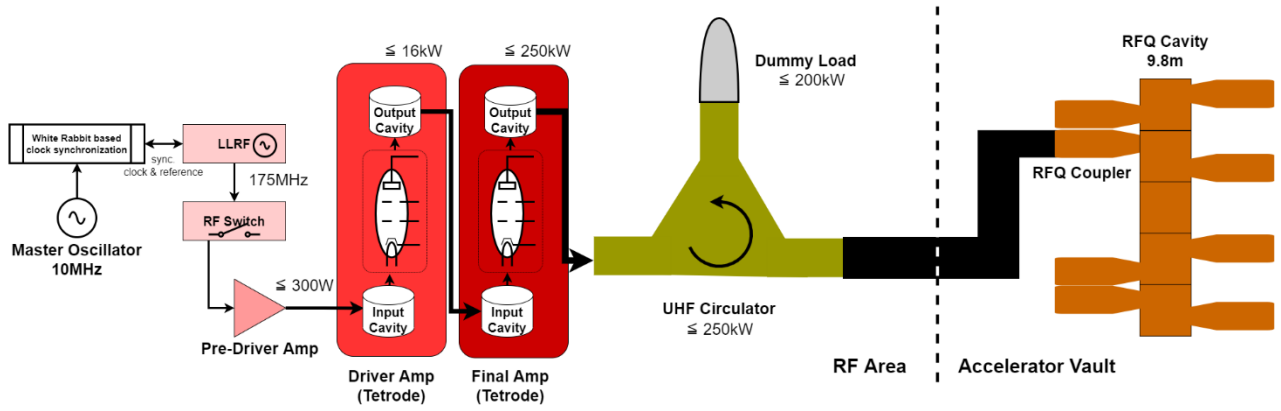

Figure 2: Illustration of 1/8 RFQ-RF amplification system.

The RFQ-RF System of LIPAc

The RFQ system of our LIPAc is working as one 9.8 m long resonator. To input 1.2 MW power including beam loading compensation, 8-synchronized RF stations are adapted as shown in Fig. 2 for one station. The reference position of the calibration is just before the RFQ-RF coupler, and RF feed power is tuned to be balanced for RFQ coupling level. This method can work on the assumption of unchanged RF-coupler conditions and the uniformed circulator conditions in any power, phase, and pulse combination. Studies about the condition and the dynamics when above assumption is broken are one of most important point in our having RF system. First point of our starting point related with the RF-coupler issue is discussing in the different report in the meeting. The later topic, the issue of circulator, is dealt with in this report.

The circulator is used to isolate the RF transmission line between tetrode system and the RF cavity to keep the coupling impedance of the tetrode cavity. Especially for the Master-Slave control, the uniformity of the circulator characteristics is also considerable important point to be optimized. The “Master” station is driven by individual mode with clock synchronization. Controlled reference amplitude and phase for the RFQ field including the pulse timing is provided from the master module, and the compensation loop of the relative offset between the master and each slave channel is applied at the point of before RF-couplers for the forward power. Because the heat load compensation of the circulator is done by active tuning of the coil current, if the characteristics of the S-parameters and the thermal effect are different among the circular of each chain, all calibrated power will be unbalanced. Circulator dynamics is closely connected with the RFQ study in the control point of view.

POWER CIRCULATION IN THE CIRCULATOR

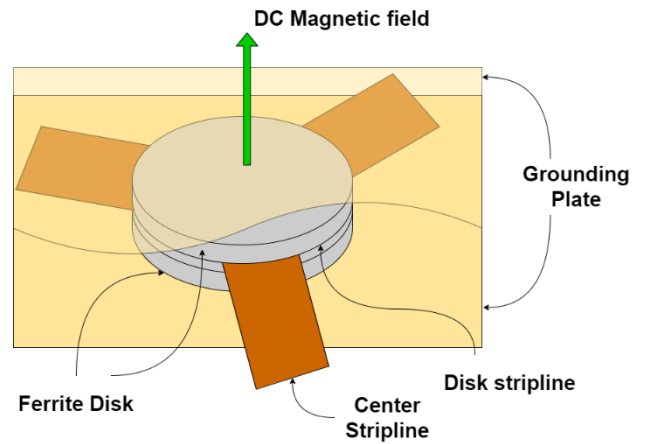

Figure 3: Minimum setup to circulate RF for 3-ports.

The circulator has been studied by the methodological approaches for a long time [6-8]. Figure 3 shows that the minimum setup of the circulator. Most of dynamics of the circulation of electromagnetic waves is determined by the resonance characteristics of the soft ferrite disk, sandwiches the stripline of the large inner conductor plate. Dynamics in the ferrite is represented by the relative permeability [8], written in Eq. (1) and (2). Rectangle brackets is representing matrix form.

$$[\mu_r] = [I] + [\chi], \quad (1)$$

$$[\mu_r] = \begin{pmatrix} \mu & -j\kappa & 0 \\ j\kappa & \mu & 0 \\ 0 & 0 & 1 \end{pmatrix}, [\chi] = \begin{pmatrix} \chi_{xx} & \chi_{xy} & 0 \\ \chi_{yx} & \chi_{yy} & 0 \\ 0 & 0 & 0 \end{pmatrix}. \quad (2)$$

The susceptibility factors χ_{ij} appeared in here can be determined by the radian frequency of the alternating radio magnetic field $\omega_{m/i}$ in the ferrite.

$$\begin{cases} \chi_{xx} = \chi_{yy} = \frac{\omega_m \omega_i}{-\omega^2 + \omega_i^2} \\ -\chi_{yx} = \chi_{xy} = \frac{j\omega_m \omega_i}{-\omega^2 + \omega_i^2} \end{cases}, \quad (3)$$

$$\begin{cases} \omega_m = \gamma M_0 \\ \omega_i = \gamma(H_0 - N_z M_0) \end{cases}. \quad (4)$$

where M_0 is the saturation magnetization [A/m], $\gamma = 2.21 \times 10^5$ is the gyromagnetic ratio [[rad/s]/[A/m]], H_0 is the applied direct magnetic field intensity [A/m], and N_z is a z-directed shape demagnetizing factor of the geometry.

The mismatch or peak shift from the ideal circulator can be happened when less uniformity of the ferrite material property and of the external magnetic field penetrating the disk, or less symmetric of the stripline geometry, typically. Later parts of the report explain the situation of the problem and the repair, tests to characterize the circulator, and the discussion to make them improved.

REPAIR AND THE PERFORMANCE TEST

Problem and the Repair

Discharge in the circulator was happened at the port-1 and the port-2. Problem of the port-1 was found in our facility when problem was happened in end of January 2022, the problem in the port-2 was found in the factory of the manufacturer. Figure 4 shows the failure of the port-1 because of bad connection between inner stripline and the transition to the coaxial line. We are guessing that the cause of this failure is thermal cycle of the screws tightened these two components. We don't know it can be deteriorated for a long-term operation or it is initially in the bad state, but the event was happened as the discharge in the small gap. As the temporal solution, we have periodic inspection for all connection parts if they are still well-tightened.



Figure 4: Broken part of the circulator port-1 (2022/Jan).

First action for the repair had been done by polishing the inner stripline and replacing the inner transition to the new one. Inner transition is completely burned and holes for the screw had been melted. The pair part of the stripline had also melted, but it was difficult to replace because one large copper plate is used to the stripline. Our on-site repair result in June 2022 is shown in Fig. 5. Damaged part was polished, but some dips are still existing. Basically, it is not a problem, because dip parts are far from the surface. We

had a 200 kW transmission test after on-site repair, and it was cleared also for the long-term stability check.

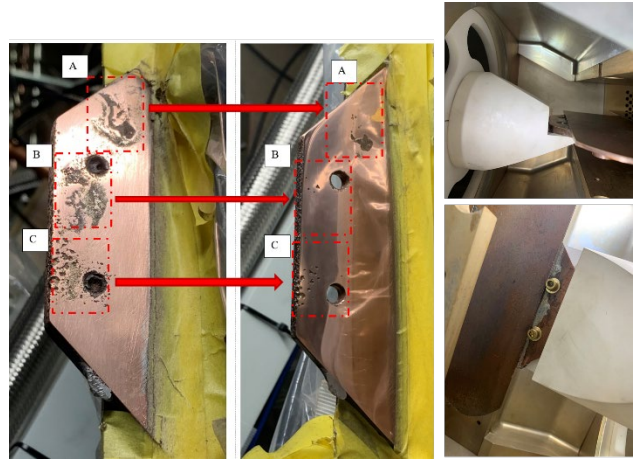

Figure 5: On-site repair for the port-1 (2022/June).

After that, because of manufacturer strong recommendation, we decided to ship it back to the factory in the US, to have an inspection by completely disassembling and reoptimizing the magnetic field of permanent magnets. As shown in Fig. 6, inner stripline was checked and they found spark traces in the port 2. After detailed check for all components, assembly and magnetic tuning was performed. The repair activity in the factory was done from July 2022 to March 2023, and the factory acceptance test was performed in February 2023 shown in Fig. 7.

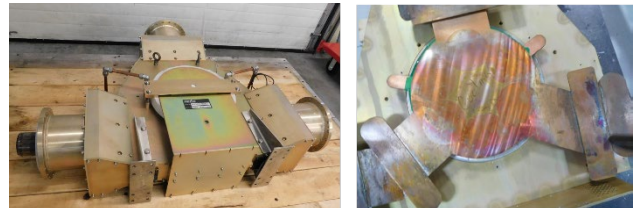

Figure 6: The circulator and the disassembled stripline.

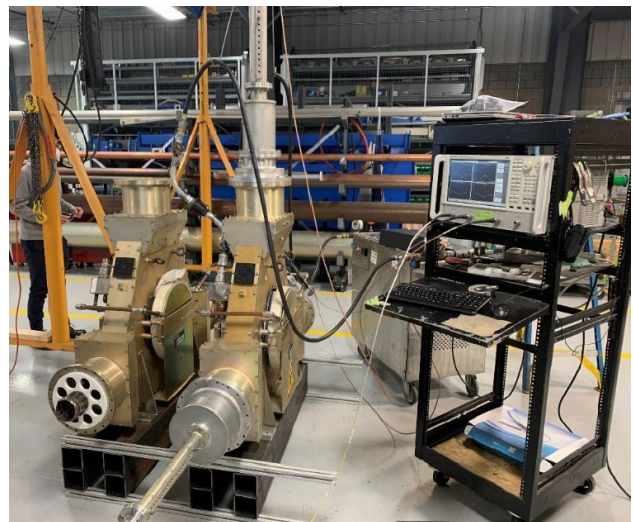

Figure 7: Measurement setup for the factory test.

In the acceptance test, we noticed that the tuning point was changed from 25.5 deg. to 30.0 deg., and the existence of the magnetic materials as the circulator support, but both influences are appeared in the Eq. (4), so we thought it would compensate by the coil current similar as the ohmic loss. In the circulator S-parameters test after delivery, we realized that our understanding in the factory test was not correct.

VNA Test for the Repaired Circulator

For the repaired circulator, after integration to our RF system, we had a test to characterize the circulator performance by S-parameters. Figure 8 shows the setup of the measurement. To know the effect of near magnetic material, 1cm thickness iron plate was inserted on the bottom of the circulator. First, we measured the resonance point of S-parameters by scanning the coil current. Next, we checked the influence of temperature change and the existence of the iron plate.

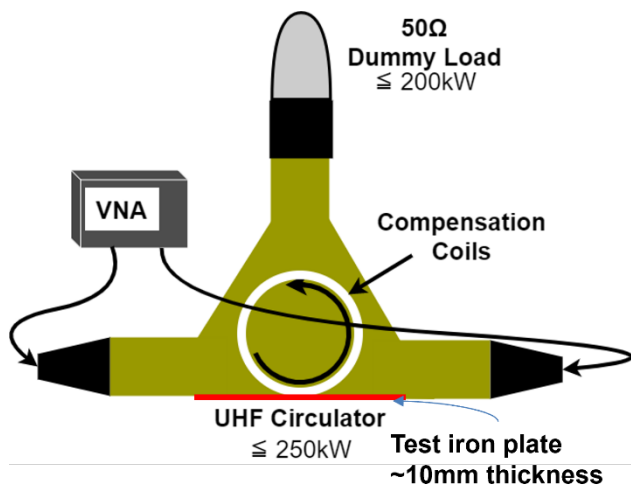

Figure 8: Setup of the VNA test for the circulator.

Resonances of each S-parameters for the repaired and optimized circulator have been performed before high-power test. Frequency response has been checked in the factory tuning, then the external compensation field was not applied. Our interesting is the response for the coil current, so we measured all of parameters again also to see the effect of transportation and construction. The result of peak scan is shown in the plots of Fig. 9. Left hand side denotes the result of optimized circulator, which is also working as the pair of the repaired one. Right hand side denotes the result of the repaired circulator. Peak points of the repaired one is a bit moved to the right side, which is higher current region. The reason why this right shift is happening is because of difference of the tuning temperature. The optimized and the repaired circulators are tuned for 25.5 deg. and 30.0 deg., respectively.

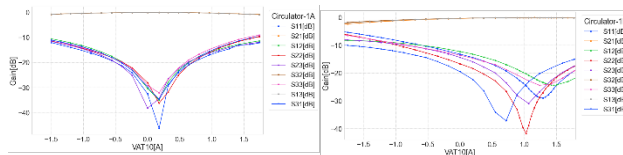

Figure 9: Measurement of the S-parameters for optimized (left) and repaired (right) circulators vs. applied coil current (abscissa).

In addition to that, the peak positions in the right-hand side plot looks different. This part is still under study, but related to this point we had a test by changing temperature and existence of the magnetic material. Figure 10 shows the characteristics change for the different temperature and with and without ~1cm thickness iron plate. Blue, orange, and green plots are, respectively, the normal condition, with inserting an iron plate, and temperature change. S_{21} have similar value, but the effect of temperature makes peak level changes. In this case, better directivity but worse return loss was observed. In the Eq. (3) and (4), contributions from temperature appeared in M_0 term and from external field H_0 are not the same. We are guessing that some part of differences is coming from there. From the operation point of view, <math>< 26\text{ dB}</math> stop band shall be no problem.

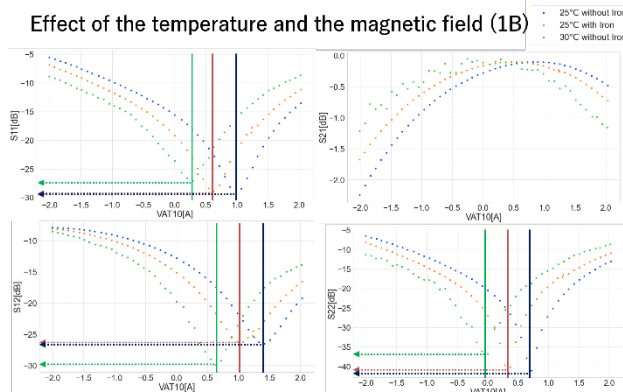

Figure 10: Illustration of the high-power test setup.

The 200kW Full Power Transmission Test to the Dummy Load

The RF transmission test for the repaired circulator was performed twice in total. The first chance is done just after onsite repair in June 2022, and the second chance was after factory repair in June 2023. In fact, we spent a lot of time to recover from the circulator failure, and we understand that many non-effective actions were taken in this series of actions, but it was good opportunity to start discussion and consideration of the circulator study as the onsite activity.

We got good result for both tests without any problem in repaired parts. Especially in the second test, we tested the circulator performance with existence of the pair circulator. The setup was illustrated in Fig. 11. In practical situation, we polarize each circulator in parallel, and so our interesting working point can be confirmed under interactions of the magnetic field including its compensation coil inducing field. As the typical result, the test term for CW-200 kW transmission was shown in Fig. 12. We successfully

cleared the test for 200 kW in CW operation for a long-term > 3 hours, which is enough to reach steady state.

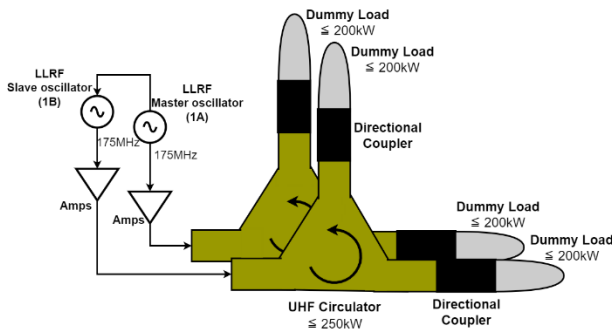

Figure 11: Illustration of the high-power test setup.

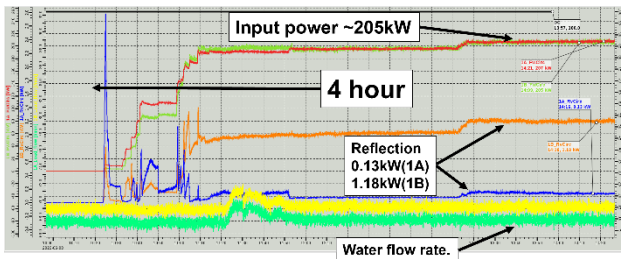

Figure 12: High-power transmission test of the repaired and its pair circulators for 4-hours in the CW mode.

The return loss of the circulator in the specification sheet checked in the cold test is more than 26dB, but 22.4dB return loss can be seen in the high-power test. The reason of this difference can be imagined because of the thermal effect comes from ohmic loss or the difference of the tuning point. We still don't understand about this part, so we must study it. Though, in any case, stable reflection could be obtained, and the return level is ~1kW in the absolute value, thus it is not a problem for the operation.

CONCLUSION AND DISCUSSION

Consequently, the circulator had been successfully repaired without whole replacement. Though our couple of RF test, we also achieved full RF functionality of 200 kW power transmission in the individual test of the RFQ-RF system. Because we are started to use the 200 kW dummy load before this commissioning phase, this is the first trial of the full functional test for the RF system to amplify and transmit the RF power up to 200 kW.

For the harvest regarding the improvement in the future, we obtained good hints to consider the circulator dynamics. Asymmetry of the circulator port and the magnetic field can induce the unbalanced scatter matrix components. As the issue of the hardware limitation, present current driver, used to the compensation coil has less flexibility for the higher duty operation. Due to the short stop, circulator temperature can be reduced much lower from the operating point. So well-designed current control will be required to the fast recovery.

Considering the difference of the cooling time between the RFQ and the circulator, it is possible improvement point to focus on studying about multi-feed RF control of

the RFQ cavity. We will continue the RF circulation study by combination of the simulation and the measurement.

REFERENCES

- [1] C. de la Morena *et al.*, "Fully Digital and White Rabbit-Synchronized Low-Level RF System for LIPAc", in IEEE Transactions on Nuclear Science, vol. 65, no. 1, pp. 514-522, Jan. 2018.
- [2] M. Weber *et al.*, "LIPAc RF Power System Engineering Design Report" (Internal).
- [3] M. Weber *et al.*, "Functional Overview of the RF Power System for the LIPAc RFQ," in IEEE Transactions on Plasma Science, vol. 49, no. 9, pp. 2987-2996, Sept. 2021, doi: 10.1109/TPS.2021.3102840.
- [4] T. Shinya *et al.*, "Integration of 175-MHz LIPAc RF System and RFQ Linac for Beam Commissioning," in IEEE Transactions on Plasma Science, vol. 48, no. 6, pp. 1489-1495, June 2020, doi: 10.1109/TPS.2020.2985020.
- [5] Ivan Moya, "LIPAc Master Oscillator and RF integration" (Internal).
- [6] H. Bosma, "On the principle of stripline circulation", The Institution of Electrical Engineers, pp137-146,1962.
- [7] D. K. Linkhart, "Microwave Circulator Design", Artech House, 2014.
- [8] J. Helszajn, "The Stripline Circulator : Theory and Practice", John Wiley & Sons, Incorporated, 2008.