

# SYNCHRONIZED BEAM POSITION MEASUREMENT FOR SuperKEKB INJECTOR LINAC

M. Satoh<sup>†</sup>, F. Miyahara, and T. Suwada, KEK/SOKENDAI, 305-0801 Tsukuba, Japan  
T. Kudou, S. Kusano, Mitsubishi Electric System & Service Co., Ltd., 305-0045 Tsukuba, Japan  
T. Ofusa, H. Satome, and M. Takagi, KIT, 300-0045 Tsuchiura, Japan

## Abstract

The SuperKEKB injector linac delivers the electron and positron beams of different properties to four independent storage rings and a positron-damping ring. The required injection beam energies are from 1.1 GeV to 7 GeV, and the amounts of bunch charges are from 0.3 nC to 10 nC. Especially, the injection beams to SuperKEKB electron and positron storage rings require the low emittance and high intensity bunch charge for the nano-beam scheme operation aiming at the peak luminosity of  $8 \times 10^{35} \text{ cm}^{-2} \text{ s}^{-1}$ , 40 times higher than the luminosity record of previous KEKB project. The Phase I beam commissioning of SuperKEKB has already been completed from February to June in 2016. The Phase II beam commissioning of SuperKEKB already started in March 16<sup>th</sup> for physics experiment. Towards Phase III commissioning of SuperKEKB, the stable beam operation with high quality beam is getting more and more important for the success of achieving the luminosity goal. For this purpose, the linac beam handling to keep the emittance as small as possible is strongly required. For this reason, we developed the synchronized beam position measurement software for the correlation analysis between the beam positions and some beam jitter sources. In this paper, we report the synchronized beam position measurement system by using around 100 monitors for the SuperKEKB injector linac in detail.

## INTRODUCTION

The KEKB project has successfully completed in the June of 2010 after more than decade long operation. During the KEKB operation, the injector linac provided the different flavors of electron and positron beams to four independent storage rings; KEKB electron, positron, PF, and PF-AR rings. The target ring for the beam injection can be switched within 20 ms since the linac parameters of timing and low-level rf phase can be arbitrary controlled up to 50 Hz for the simultaneous top up injection of three rings excluding PF-AR. The achievement of simultaneous top up injection gave a strong impact on the great success of KEKB project. It improves the KEKB and PF stored current stabilities up to 0.05% and 0.01%, respectively [1].

For the SuperKEKB project [2], the injector linac upgrade and beam commissioning have been progressed since the final stage of KEKB project [3]. Figure 1 shows the layout of SuperKEKB injector linac with the total length of 600 m. Here, the beam energy at the J-ARC

section is decreased from 1.7 GeV to 1.5 GeV since the main ring energy of electron is changed from 8 GeV to 7 GeV. It is effective for grabbing a standby klystron in SectorA and SectorB. For the SuperKEKB injector operation, the most challenging issue is the high bunch charge transportation of low emittance beam. It is strongly required to the nano-beam scheme operation of the main ring for getting the high luminosity. For the high intensity positron generation, the flux concentrator and 10 large aperture S-band accelerating structures have been manufactured and installed into the beam line. As a low emittance and high intensity electron source, we have developed and installed a new photocathode rf gun cavity based on a noble new scheme in the summer of 2013. In addition, a new laser system has been also developed and worked well [4].



Figure 1: Schematic layout of the SuperKEKB injector linac. It comprises two straight sections of 120 m and 500 m long. They are connected 180 degree bending section. The both electron sources of thermionic and photo cathode rf gun are situated at the most upstream end of the injector linac.

## BEAM POSITION MONITOR READOUT SYSTEM

### Previous System

For the stable beam operation, the beam monitors are significantly important for getting information of beam bunch length, transverse profile, bunch charge, beam position, and so on. The beam position monitor (BPM) is one of the essential monitor for the accelerator beam control. In the SuperKEKB injector linac, around 100 strip line type BPMs have been installed and utilized for the daily beam operation and various feedback systems [5].

In the beginning of the KEKB project, a first BPM readout system have been developed for the injector linac. It was comprised of a VME bus based CPU module with a MC68060 microprocessor of 50 MHz, a digital oscilloscope, and a cable combiner box. The digital oscilloscope has the performance with the sampling rate of 5 GHz, the vertical resolution of 8 bits, and the analog

<sup>†</sup> masanori.satoh@kek.jp

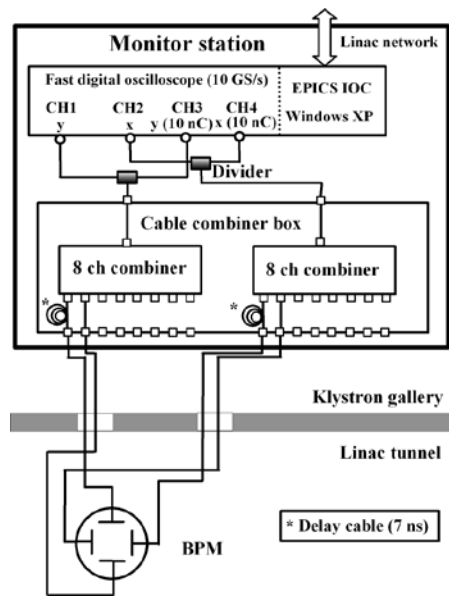

Figure 2: Schematic drawing of the previous BPM readout system by using a fast digital oscilloscope based on the Windows operating system. One monitor station is comprised of an oscilloscope and a cable combiner box. It processes the analog signal from about 4 BPMs.

bandwidth of 1 GHz. The CPU module and the digital oscilloscope was communicated via GPIB bus. The client software showing beam orbit information can get the data of calculated beam position and bunch charge from the CPU module via linac control network. The speed performance of this system is around up to 1 Hz, which is limited by the communication speed of GPIB bus. The control system software was a in house system based on remote procedure call.

Towards the simultaneous top up injection of KEKB electron, positron, and PF rings, the beam position measurement up to 50 Hz was getting important. For this reason, the new BPM readout system has been developed and installed [6, 7]. We have adopted a WindowsXP based fast digital oscilloscope with the sampling frequency of 10 GHz, the vertical resolution of 8 bits, and the analog bandwidth of 1 GHz. We have continued to utilize the existing BPM heads and cable combiner boxes. Around 20 monitor stations process the analog signal from about 100 BPMs. One monitor station calculates the horizontal, vertical beam positions and bunch charge by using the analog waveform from BPMs through the cable combiner box as shown in Fig. 2.

In this system, CH1/CH2 and CH3/CH4 are used for the low bunch charge modes and the high bunch charge mode, respectively since it is impossible to change the vertical scale of oscilloscope in every 50 Hz. The low bunch charge mode from 0.1 nC to 1 nC are utilized for the light source injection and KEKB electron ring injection. The high bunch charge operation around 10 nC is utilized as the primary electron impinging on tungsten target for positron beam production. The control software

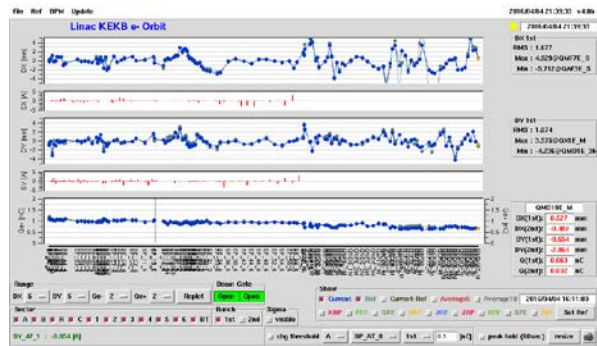

Figure 3: Beam orbit panel developed by Python/Tk script. The plots show the horizontal (top), vertical (middle) beam positions in the units of mm, and bunch charge in the unit of nC at each BPM location through the electron gun to the end of beam transport line.

of this system has been developed with Experimental Physics and Industrial Control System (EPICS) framework [8]. We have developed the EPICS Input/Output Controller (IOC) for this system by using Microsoft Visual Studio 2005 C++, TekVisa, and EPICS base R3.14.8.2 environments. Figure 3 shows the example of beam orbit display panel developed by using Python scripting language. The calculated beam position and bunch charge data can be accessed via EPICS process variables (PV). These PVs are utilized for many high-level applications like an energy feedback system. The repetitive data acquisition speed performance of this system is up to around 150 Hz with the data length of 20 k points and simultaneous 4 channels measurement.

### Current System

The previous BPM readout system has the beam position measurement precision of about 50  $\mu\text{m}$ , which is enough performance for the KEKB project. However, the low emittance beam handling with the high bunch charge is one of the key goal indicators for the SuperKEKB injector linac. The precise alignment of accelerating structures and magnets less than 100  $\mu\text{m}$  is strongly required to avoid the emittance growth caused by the transverse wake field effect. The high precision beam position measurement and control is necessary since high quality alignment is practically much difficult. For this reason, a new BPM readout system based on VME card has been developed and installed [9, 10].

The current BPM readout system consists of a VME CPU of MVME5500, a RAS board, an event receiver module (EVR), and a BPM readout board with four analog input channels. The BPM readout board is comprised of a main FPGA, four sub FPGA, four ADCs with the sampling frequency of 250 MHz, and the vertical resolution of 16 bits. In addition, it equips three variable attenuators, two band pass filters (BPFs), one low pass filter, two low noise amplifiers, and one calibration pulser for each input channel. The band pass sampling technique with the combination of 4<sup>th</sup> order Butterworth filter and 2<sup>nd</sup> order Bessel filter can make a high precision beam

position measurement up to 3  $\mu\text{m}$ . It was convinced that the beam position measurement precisions of all BPMs are less than 10  $\mu\text{m}$ . It satisfies with our final goal. The EPICS IOC as a control software is built by using EPICS base R3.14.12 running on VxWorks 6.8.3.

## SYNCHRONIZED BEAM POSITION MEASUREMENT SYSTEM

A synchronized beam position measurement system (SBPMS) is developed as the EPICS IOC with the EPICS base R3.14.12 running on the Linux of CentOS version 5 or 6. The SBPMS is monitoring the all waveform type PVs of 23 monitor stations. One waveform PV contains the horizontal, vertical beam positions, bunch charges of 1<sup>st</sup> and 2<sup>nd</sup> bunch for each BPM, the beam shot ID, and so on. The beam shot ID is delivered from the event generator module (EVG) to EVR installed in the BPM readout VME chassis. It is a cyclic counter of 16 bits. By comparing the beam shot ID, the SBPMS can collect only exactly synchronized beam shot data over all 23 BPM readout stations.

The SBPMS contains 12 EPICS PVs as follows. (1) and (2) are the waveform type PVs containing the BPM name information and the description about the data containing order in the DATA PV as the string characters. There are 10 DATA PVs of (3) corresponding to 10 different beam modes. The beam mode identifier is the last part of PV name which is presented by 3 characters like KBE, KBP, and so on.

- (1) LliBM:BPM\_SYNC:NAMELIST
- (2) LliBM:BPM\_SYNC:PROPLIST
- (3) LliBM:BPM\_SYNC:DATA:[BeamMode]

If the SBPMS cannot obtain the updated PV data from the BPM EPICS IOC until the predefined timeout value, the corresponding parts of synchronized beam position data are filled with zero values. Even in such case, the high-level applications can use the updated synchronized PVs including some zero values.

In the SuperKEKB injector linac, the fast rf monitor has been also developed and utilized for the daily operation [11]. This monitor also can handle the beam shot ID provide by the EVG system. The similar synchronized data management IOC is now under development about the rf monitor. We have a plant to compare the synchronized shot-by-shot data between the BPM data, rf phase data, and rf amplitude data in the near future. In addition, the similar framework will be applied to also the pulsed magnet control system [12]. Eventually, the comparison among the BPM data and the other monitor system data for each exact same trigger shot could give some useful information to find the beam jitter origins [13].

## CONCLUSIONS

The synchronized beam position measurement framework is developed for the SuperKEKB injector linac. This system is the EPICS IOC running on the Linux server computer. The similar framework will be applied

to the other systems like the rf monitors and pulsed magnet controllers. Eventually, the correlation analysis between the beam position and other data could bring us the detailed information about the source of beam fluctuation. It will be greatly helpful for the high quality beam operation required for the SuperKEKB Phase III commissioning.

## REFERENCES

- [1] M. Akemoto *et al.*, Prog. Theor. Exp. Phys., 2013, 03A002.
- [2] Y. Ohnishi *et al.*, "Report on SuperKEKB Phase 2 Commissioning", MOXGB1, in these proceedings (*IPAC'18*), Vancouver, British Columbia, Canada, Apr. to May 2018.
- [3] M. Satoh *et al.*, "Commissioning Status of SuperKEKB Injector Linac", MOPMF075, in these proceedings (*IPAC'18*), Vancouver, British Columbia, Canada, Apr. to May 2018.
- [4] R. Zhang, X. Zhou, T. Natsui, Y. Ogawa, and M. Yoshida, "Yb/Nd Doped Hybrid Solid Laser of RF Gun and Beam Commissioning for Phase-II of SuperKEKB", WEPML060, in these proceedings (*IPAC'18*), Vancouver, British Columbia, Canada, Apr. to May 2018.
- [5] T. Suwada, N. Kamikubota, H. Fukuma, N. Akasaka, and H. Kobayashi, "Stripline-type beam-position-monitor system for single-bunch electron/positron beams", Nucl. Instr. Methods in Physics Research A 440, 2000, pp. 307-319.
- [6] M. Satoh, T. Suwada, K. Furukawa, Y. Hu, T. Kudou, and S. Kusano, "EPICS IOC of WINDOWSXP-Based Oscilloscope for Fast BPM Data Acquisition System", in *Proc. ICALEPCS2009*, Kobe, Japan, 2009, pp.567-569.
- [7] T. Aoyama, T. Nakamura, K. Yoshii, N. Iida, M. Satoh, and K. Furukawa, "Upgrade of Readout System for Beam Position Monitors in the KEKB Beam Transport Line", in *Proc. ICALEPCS2009*, Kobe, Japan, 2009, pp.495-497.
- [8] M. Satoh, K. Furukawa, K. Mikawa, F. Miyahara, Y. Seimiya, T. Suwada, K. Hisazumi, T. Ichikawa, T. Kudou, S. Kusano, Y. Mizukawa, H. Saotome, and M. Takagi, "Control System Status of SuperKEKB Injector LINAC", in *Proc. ICALEPCS2015*, Melbourne, Australia, Oct. 2015, pp.170-172.
- [9] R. Ichimiya, T. Suwada, M. Satoh, F. Miyahara, and K. Furukawa, "High Position Resolution and High Dynamic Range Stripline Beam Position Monitor (BPM) Readout System for the KEKB Injector Linac towards the SuperKEKB", in *Pro. IBIC2014*, Monterey, USA, Sep. 2014, pp.637-641.
- [10] F. Miyahara, K. Furukawa, M. Satoh, Y. Seimiya, T. Suwada, R. Ichimiya, and H. Saotome, "High Position Resolution BPM Readout System with Calibration Pulse Generators for KEK e<sup>+</sup>/e<sup>-</sup> Linac", in *Proc. IBIC2015*, Melbourne, Australia, Sep. 2015, pp. 369-372.

- [11] T. Matsumoto, H. Katagiri, M. Akemoto, D. Arakawa, T. Miura, F. Qiu, and Y. Yano, “RF Monitor System for SuperKEKB Injector Linac”, WEPAK016, in these proceedings (*IPAC'18*), Vancouver, British Columbia, Canada, Apr. to May, 2018.
- [12] Y. Enomoto, K. Furukawa, T. Natsui, M. Satoh, and H. Saotome, “A New Pulse Magnet Control System in the KEK Electron Positron Linac”, WEPAK014, in these proceedings (*IPAC'18*), Vancouver, British Columbia, Canada, Apr. to May 2018.
- [13] Y. Seimiya, T. Higo, and M. Satoh, “Beam Jitter and Emittance Simulation to Realize Real Accelerator Performance”, MOPMF074, in these proceedings (*IPAC'18*), Vancouver, British Columbia, Canada, Apr. to May 2018.